

编号 No	
发行日 Date	2008年6月4日

# 式样书

## SPECIFICATION

品名 : 制冷机芯  
Product: Cooler unit

型式 : BV-2C  
Type : BV-2C

接收盖章栏 Approved by

请在盖章后交回 1 份  
Please return one after your stamp

承认 approver	确认 checker	制作 maker

**修订履历**  
Revised curriculum vitae

记号 Code	年月日 Date	修订理由 Reason for revision	负责人 person in charge
博通(香港)商貿有限公司 BOKTONG (H. K.) CO., LIMITED			

1. 适用范围

本式样书对于 制冷机芯 适用。

This specification is applied to the cooling unit supplied by Qinhuangdao Fulianjing Electronic Co.,Ltd .

2. 形式及名称 Model and Name

本式样书规定的产品名称为 制冷机芯  
型号为 BV-2C

The name of the product is Refrigeration unit.

Model Number is PV-2HF in this specification.

3. 式样 Spec

项 目 item	式样 Specifications
种 类 kind	制冷机芯 cooler units
外形尺寸 (长×宽×高) dimension (length x Width x height)	70×70×30mm
制冷方式 Cooling way	铝板制冷 cooling Aluminum Plate
散热方式 Heat Dissipation method	铝板散热 (加散热片) Aluminum Plate (attached fan)
绝缘耐压 Insulation voltage	AC1200V, 1秒间 (散热铝板 - 端子间) AC1200V, within 1S (between hot side aluminum and terminal)
绝缘电阻 Insulation resistance	DC250V, over10MΩ (散热铝板 - 端子间) (between hot side aluminum and terminal)
使用温度范围 using temperature range	0~35℃
制冷铝板温度范围 temperature range of cooling plate	-19~59℃
使用湿度范围 using humidity range	30~85%RH
总 质 量 total weight	约200g
存放温度范围 storage temperature range	-20~70℃
存放湿度范围 store humidity range	10~90%RH 但是不允许有结露 But condensation is not allowed
机芯内部电阻值 resistance for inner peltier	1.48~1.82Ω (※1)
最大使用电压 Maximum voltage supplied	DC ±12V
最大电流 Imax	7.0A
最大吸热量 (实测值) Qmax(test value)	42W (温度差:0℃、Tc=Th=50℃)
最大温度差 (实测值) ΔTmax(test value)	84.9℃ (吸热量:0W、Th=50℃)
额定电压、电流 Rated voltage, current	DC ±12V 5.5A
机芯构造 Cooling unit structure	按照 C2JS281980800-PD-WL/1.0

※1 周围温度为25±1℃、用4端子交流电阻仪(1kHz)测定

Tested with four terminals ac resistance meter (1KHZ) and the ambient temperature is 25 + / - 1℃

#### 4. 制冷特性 cooling characteristics

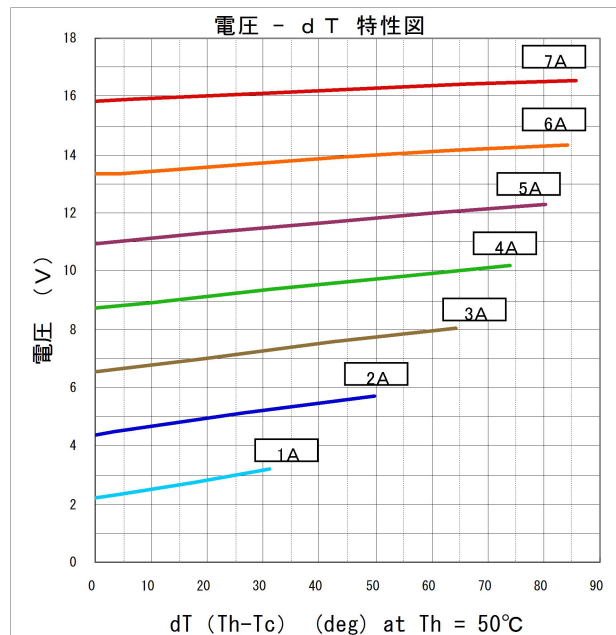
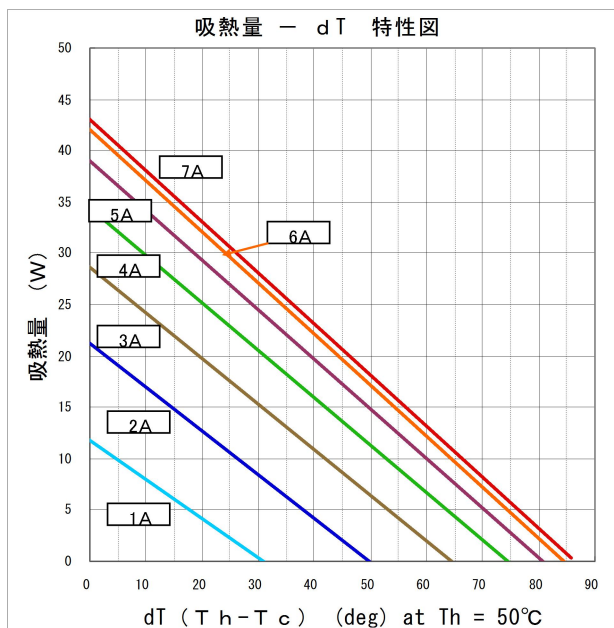

- \* Th: BV-2C 的散热面表面温度  
Surface temperature of hot side
- \* Tc: BV-2C 的制冷面表面温度  
Surface temperature of cold side
- \* 本特性图不是以『半导体两端温度』为基准进行的理论计算、而是根据在真空中对散热 / 制冷两个表面温度进行的实测值制定的。  
This performance curve is not got from theoretical calculation base on the temperature of peltier's two sides, but the tested date of the hot and cold sides' temperature under the vacuum condition.  
请注意: 根据实际使用的热交换器的性能的差异, 实际测得的特性可能会降低。  
Please Note: The actual measured character may be reduced depending on the performance of the heat exchanger used.

#### 5. 使用方法 How to use

##### 5-1 机芯的安装 installing of the cooling unit

对于被冷却体及散热片的安装, 用热传导性凝胶 (或热传导性粘接剂) 在制冷机芯侧的安装面均匀地涂抹, 然后再用均等的力拧紧机芯的固定螺丝。For mounting the cooling body and heatsink, spread heat conductive gel (or thermal conductivity adhesive) on the installing surfaces uniformly, then tighten the fixed screws with equal force. Please note that there are bubbles and foreign objects in the thermal conductive gel (adhesives), which reduces cooling and heat dissipation performance.

请注意: 如果热传导性凝胶 (粘接剂) 中有气泡或异物的话, 制冷及散热的性能会降低。

Please note: The performance of cooling and heat dissipation will be reduced if there are bubbles or foreign objects in the thermal conductive gel (adhesives).

\*\*\*注意\*\*\*

1) 一定在制冷机芯散热侧安装散热片后使用。

如果不安装散热片的话, 对制冷机芯的可靠性会造成影响。

The cooler unit must be used after installing heat sink on it's hot side. Otherwise, the reliability will be affected.

2) 为了不使机芯结露, 请在箱体侧施加对策。

To prevent the cooler unit from condensation, please apply countermeasures on the side of the case .

3) 在安装固定散热片的螺丝时, 请一定使用垫片及弹簧垫片。(扭矩: 1N·m)

When installing and fixing the screws of the heat sink, be sure to use washers and spring washers. (torque: 1 N · m)

(用粘接剂固定的场合可以只使用螺丝)

Screws may be only used in the case of adhesives fixation.

拧螺丝时请交替、均等地进行。

Tightening the screws alternately and evenly.

4) 尽量避免使用热传导性润滑脂(短期间的使用没有问题、但长期使用的话会导致界面热电阻增加)

Avoid using thermal conductivity grease as far as possible (no problem for short time using, but the interface thermal resistance will be increases after long time using.)

5) 如果在安装对象的表面有翘曲的话(平面度 5/100mm 以上)、对性能及可靠性会产生影响。

If there is warping on the surface of the installation object (flatness above 5/100mm), the performance and reliability will be affected.

6) 关于使用状态, 请不要在机芯本体上施加超过 100N 的拉力

Please do not apply more than 100N tensile force on the body of cooler .

7) 请不要只拿导线部分移动机芯, 这样的话会造成断线。

Please do not only take a part of the wire to move the cooler, otherwise, it will be broken.

8) 以加热为目的使用时, 请注意制冷面(此场合变为加热面)的温度上升, 表面温度不要超过 60°C。

When used for the purpose of heating, please note the temperature of cooling surface will rise (cooling surface change to heated surface on this condition) .The surface temperature can not over 60 °C.

9) 进行温度控制的场合, 推荐使用通过控制电压(电流)来进行温控的缓和方式的控制方法。

ON-OFF 控制基本是不可以的。P W M 方式等的脉冲控制没有问题, 但此场合时的脉冲幅度请控制在 2 msec 以下。

In the case of the temperature need to be controlled ,temperate temperature control control by controlling the voltage (current) is recommended.

On-off control is basically not recommended . There is no problem with pulse control by PWM and so on, but please control the pulse amplitude below 2 msec for this occasion.

## 5-2 接线 Connecting wire

制冷动作的场合(有插孔的面是制冷侧), 连接器的 1 号接线柱为+侧、2 号接线柱为一侧。

Where the cooling action is performed (the face with the jack is the cooling side), the # 1 binding post of the connector is positive pole, and the # 2 binding post is negative pole

## 6. 发货检查 Dispatching check

### 6-1 制冷机芯内部电阻值检查 Resistance of inner peltier

周围温度 25±1°C、用 4 端子交流电阻仪(1kHz)检测

Tested with four terminals ac resistance meter (1 KHZ)and the ambient temperature is 25 + / - 1 °C

全数检查

Exhaustive test

### 6-2 制冷性能检查 Inspection of cooling performance

给制冷机芯施加直流电压直, 通过 Cool Down(制冷能力)的特性来测定(无负荷)

Apply DC voltage to the cooler unit , measure the Cool Down (without load)

全数检查

Exhaustive test

### 6-3 绝缘检查 Insulation inspection

测试导线和制冷侧及散热侧铝板之间的绝缘耐压以及绝缘电阻

Test the insulation voltage and insulation resistance between the wire and the aluminum plates of the cold side and hot side.

全数检查

Exhaustive test

### 6-4 漏水检查 Leak check

把制冷机芯浸入到 50~60℃的温水中，确认从机芯内部无气泡产生。

Putting the cooler unit into the warm water with the temperature 50 ~ 60 °C, confirm there is no air bubbles risen from the inner of the cooler unit.

全数检查

Exhaustive test

### 6-5 外观检查 appearance inspection

确认在制冷面、散热面无胶的残余凸起等。

Confirm there is no residual protrusion of the residual glue on the cooling surface and hot surfaces.

## 7. 包装 package

对于制冷机芯的包装要使用专用的包装箱，或在搬运时产品不易损伤的包装箱。

Using special packaging boxes, or others that is not easy to be broken during transport.

## 8. 注意事项 Attention

8-1 对于制冷机芯的通电请一定在规定电压范围内进行。

Be sure to apply the power under the specified voltage range to the cooler unit .

8-2 请在散热侧一定安装散热片，在向箱体安装时请通过散热风扇等尽可能降低散热片的温度。

Please install the heat sink on the hot side, and reduce the heat sink temperature as much as possible by installing heat sink fan .

8-3 请注意：制冷机芯从高处掉落时，有破损的可能。

Please note: The cooler unit may be damaged when it falls from high.

8-4 如果制冷机芯受到撞击的话，由于安装面的铝面产生变形会对制冷能力产生影响，此种情况下请暂时不要使用。

If the cooler unit is impacted, the cooling capacity will be affected because the deformation of aluminum mounting surfaces .Please do not use it for the time being.

8-5 请不要使制冷机芯的导线（体引出的部分）受到撞击、反复折曲。（容许弯曲范围： R 10mm 以上）

Please do not hit and repeated bend the wire (the part from the body).(permissible bending range: R 10mm or above)

## 9. 其他 Else

在本式样书的规定范围内，出于提高产品性能的目的，使用零部件有部分变更的可能。

Within the standards of this specification, the using part may be partially modified for the purpose of improving the performance.

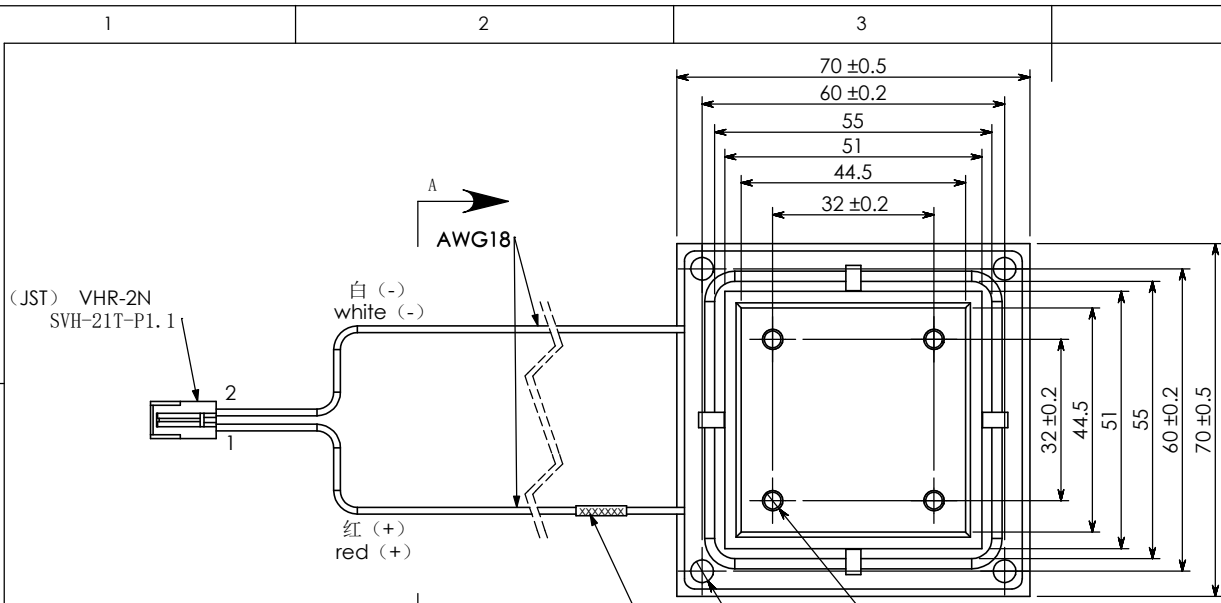

零件号 Part number	零件名称 Part Name	说明 instructions	数量 number
1	端子连接器 Terminal connection organ		1
2	半导体制冷器 Semiconductor chiller		1
3	树脂框 Resin frame		1
4	热端铝板 Hot end aluminum plate		1
5	冷端铝块 Cold end aluminum block		1

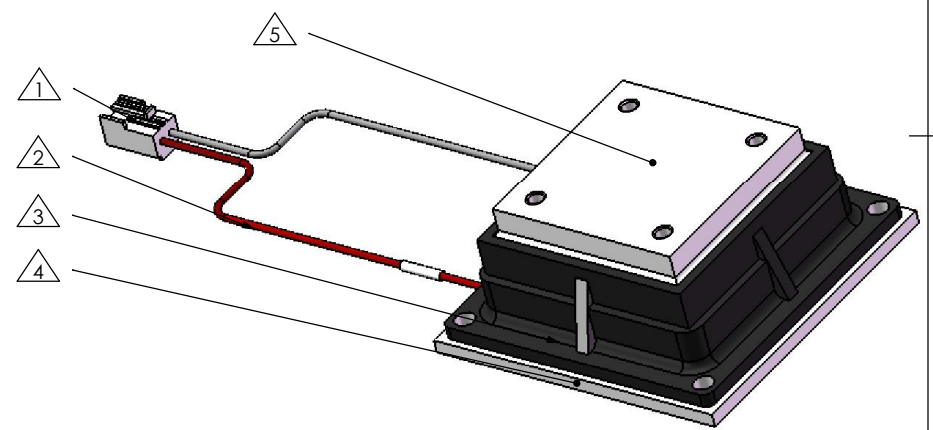
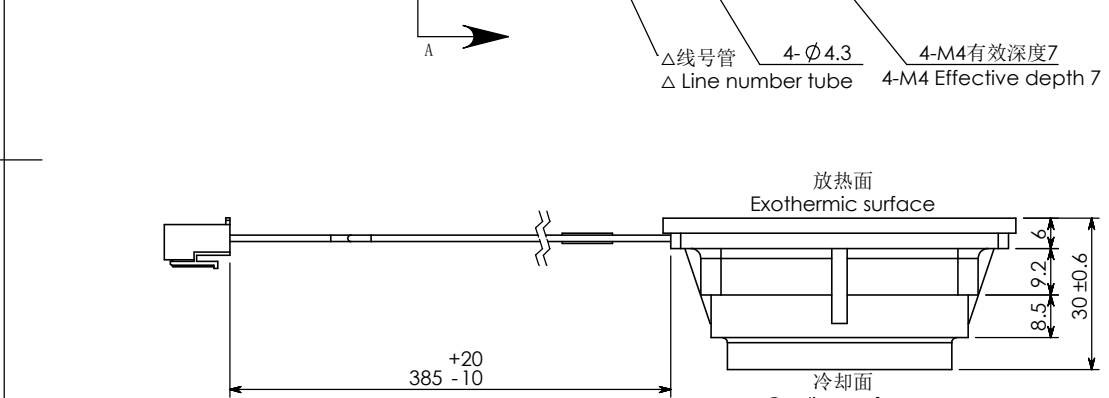
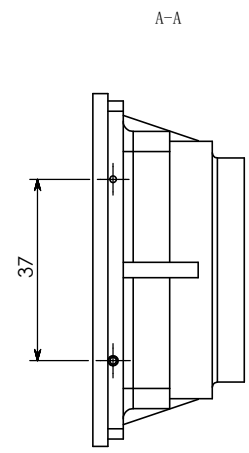

技术要求:  
 1.表面无划伤、磕碰伤。  
 2.未标注公差按照右下角公差表。  
 注: Δ线号管编号规则: "年份"+"月份"+"顺序号"  
 年份取最后一位, 月份为1-9、X、Y、Z,  
 X、Y、Z分别代表10月、11月、12月, 顺序号为五位。  
 例子:  
 2018年10月顺序编号为00001  
 打号为"8X00001"

Technical requirements:  
 1. There is no scratch or bump on the surface.  
 2. Unmarked tolerances follow the tolerance table in the lower right corner.  
 Note: Line number rule: "year" + "month" + "order number"  
 The year takes the last place, the months are 1-9, X, Y, Z,  
 X, Y, and Z represent October, November, and December, respectively,  
 and the order number is five.  
 Example:  
 October 2018, serial number 00001.  
 Type "8x00001"

范围	公差±		极限偏差数值			
	0.05	0.1	0.2	0.3	0.4	0.6
~6	0.05	0.1	0.2	0.3	0.4	0.6
>6~30	0.1	0.2	0.3	0.4	0.6	0.8
>30~120	0.15	0.3	0.4	0.6	0.8	1.0
>120~400	0.2	0.5	0.6	0.8	1.0	
>400~1000	0.3	0.8	0.9	1.0		
角度	1°	2°	3°	5°		
标记	处数	更改文件号	签字	日期		
设计			绘图日期			
审核			审核日期			
批准			批准日期			

BV-2C外形图  
 BV-2C External Chart

图号: T2KF18000-01/1.0

图样标记	重量	比例
		1: 1.5
共 1 页		第 1 页
博通(香港)商贸有限公司 BOKTONG(H.K.)CO.LIMITED		